



<b>Report No:</b> PCINER-01-PTDG	
<b>Title:</b>	
NEBT Post-Tensioned Design Guidelines	
<b>Developing Organization:</b>	
Precast/Prestressed Concrete Institute New England Region Technical Committee Phone – 888-700-5670 Email – contact@pcine.org Website – www.pcine.org	
<b>Report Date:</b>	<b>Revision Date:</b>
June 2001	
<b>Status of Report:</b>	
Final	
<b>Abstract:</b>	
<p>This report covers design, detailing and construction specifications for post-tensioning and splicing of the New England Bulb Tee (NEBT) girder. Splicing of the girders allows for longer span lengths and the elimination of intermediate bridge piers. Post-Tensioning can be used to make bridges continuous. If a State standard exists it will take precedence over these guidelines and details.</p>	
<b>Number of Pages:</b> 27	

PCI cannot accept responsibility for any errors or oversights in the use of this material. The user must recognize that no guidelines or regulations can substitute for experienced judgement. This guideline is intended for use by personnel competent to evaluate the significance and limitations of its contents and able to accept responsibility for the application of the material it contains.

	<b>NEBT Post-Tensioned Design Guidelines</b>  <b>Report Number PCINER-01-PTDG</b>	<b>Date Issued</b> <b>June 2001</b>
		Date Revised
		Page Number 1

*Table of Contents*

Introduction..... 3  
 New England Bulb Tee Girder (NEBT)..... 4  
 Design Guidelines ..... 6  
     Design References..... 6  
     Important Design Steps ..... 6  
     Important Design Issues ..... 6  
     Computer Programs ..... 7  
     Example Bridges ..... 8  
 Detailing Guidelines ..... 9  
     Detailing Issues..... 9  
         Post-Tensioned Duct Clearance..... 9  
         End Anchorage Block Dimension ..... 9  
     Guideline Drawings ..... 10  
 Example Construction Specification ..... 139  
 References..... 27

	<b>NEBT Post-Tensioned Design Guidelines</b>	<u>Date Issued</u> June 2001
	<b>Report Number PCINER-01-PTDG</b>	Date Revised
		Page Number 2

# Introduction

The New England technical committee of the Prestressed/Precast Concrete Institute has prepared these standards for post-tensioning and splicing of the New England Bulb Tee (NEBT) girder. This precast girder standard is quickly gaining acceptance through its increasing use on bridge projects throughout the region. Splicing of the girders allows for longer span lengths and elimination of intermediate bridge piers. This informational draft report covers design, detailing and construction specifications.

	<b>NEBT Post-Tensioned Design Guidelines</b>	<u>Date Issued</u> June 2001
		Date Revised
	<b>Report Number PCINER-01-PTDG</b>	Page Number 3

# New England Bulb Tee Girder (NEBT)

The NEBT girder is available in beam types ranging from 1000 mm to 1800-mm in depth. The standardization of this girder will allow efficient reuse of the contractor's forms helping to reduce costs. Beam properties for the NEBT can be found in MassHighway Bridge Manual [1] Drawing Number 6.1.3 and the PCI Bridge Manual [6].

## Other important NEBT Details from MassHighway Manual

- Strand Location and Hold Down Details (Drawing 6.1.4)
- Typical Section (Drawing 6.1.5)
- Long. Section at Support (Drawing 6.1.6)
- Prestress Notes (Drawing 6.1.7)
- Intermediate Diaphragm Detail (Drawing 6.1.11)

	<b>NEBT Post-Tensioned Design Guidelines</b>	<u>Date Issued</u> June 2001
		Date Revised
	<b>Report Number PCINER-01-PTDG</b>	Page Number 4

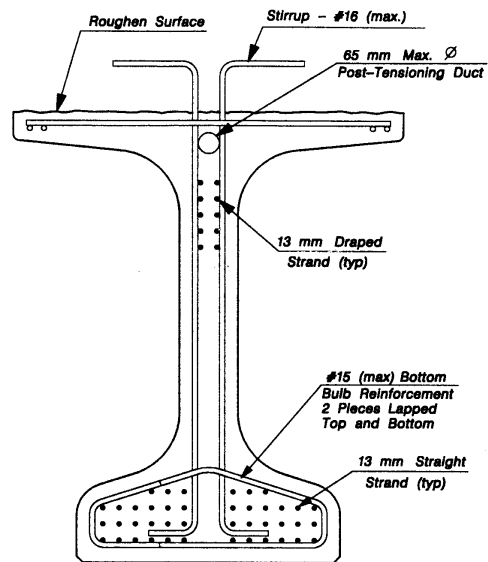

**New England Bulb Tee Girder**

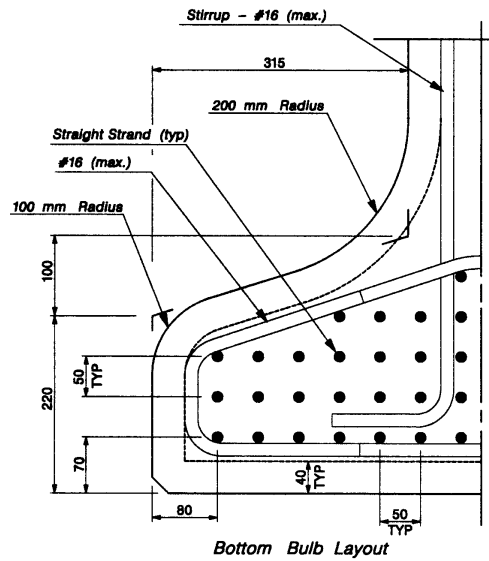

FEB 98

**Figure 1 – PCI Bridge Manual**

# Design Guidelines

## Design References

- PCI Bridge Design Manual – 1997
  - Includes NEBT Design Charts
- AASHTO LRFD Section 5 – Concrete Structures (SI)
  - Section 5.10.9 Post-Tensioned Anchorage Zones
- PCI “State-of-the-Art of Precast/Prestressed Concrete Spliced-Girder Bridges, 1992
- Caltrans-PCMAC Informational Draft [2]
- AASHTO Standard Specifications for Highway Bridges Section 9.21 Post-Tensioned Anchorage Zones
- California Prestress Manual

## Important Design Steps

The designer must determine a detailed construction sequence and time schedule for the bridge construction. This forms the basis for input into a time dependent analysis by a computer program. Assumptions must be documented since the bridge may not actually be built according to this hypothetical schedule.

## Example Construction Sequence

1. Stress P/S tendons
2. Cast girder
3. Release tendons
4. Remove girders from bed
5. Store girders
6. Erect girders
7. Install continuous P/T tendons
8. Post-tension continuity tendons
  - May be sequenced and staged to make design more efficient
9. Place deck slab
10. Post-tension continuity tendons?
11. Add railing and other superimposed loads
12. Apply live load

## Important Design Issues

### Staging of Post-Tensioning

The designer should investigate the economics and design savings of staging the overall post-tensioning. Many designs perform partial post-tensioning after girder erection and complete the process after the deck is poured.

	<b>NEBT Post-Tensioned Design Guidelines</b>	<u>Date Issued</u> June 2001
		Date Revised
	<b>Report Number PCINER-01-PTDG</b>	Page Number 6

### Use of a Temporary Support

A temporary support placed underneath the girder splice may help in reducing temporary post-tensioning and help constructability. However, due to traffic considerations this may not be a viable option. A possible alternative may be to splice the girders on the ground at the site, and then lift them into their final position.

### General Zone Reinforcement

The design of General Zone Reinforcement such as spalling and edge tension reinforcement as it pertains to the NEBT is important. The AASHTO Specifications discuss various analysis methods including Strut-and-Tie modeling, elastic stress analysis or approximate methods. A general rule of thumb to be used is to have any spalling reinforcement able to resist 2% of the factored tendon force. Detailing is important such as placement of spalling reinforcement as close to the concrete face as possible and have such reinforcement tie together adjacent anchorage.

### Maximum Force Variation

A note similar to that used on Caltrans post-tensioned box girder projects will be used. See 'Post-tensioning' notes page on guideline drawings.

### Future Redecking

If the deck may be removed and replaced at a future date, this should be taken into account during the initial design stage.

### Length of Splice and Pertinent Details

We are proposing a 250 mm splice length for straight tangent girders. For girders placed on chords to follow the horizontal curvature of deck, the splice length may have to be increased to keep the horizontal curvature in the tendons at a reasonable radius. The girder webs may have to be widened in the splice region to prevent lateral pop-out of the curved tendons. It is important that a decision be made early whether the splice will be required to carry any girder dead load shear prior to post-tensioning. If this is the case a full shear friction design should be completed to accommodate such loads. A more efficient and popular option is to stage the construction so that these large shear forces are not present, i.e. post-tension prior to removal of temporary shoring.

### Shear Key Design

We are proposing to use several small-standardized rectangular keys with the number of keys to be determined by the designer. Actual design of such keys (what analysis to use) is currently under discussion.

### Computer Programs

There are computer programs out on the market that account for the 'Time Dependent' effects on the loading of the spliced girders. The Caltrans-PCMAC design example [2] used the program 'ADAPT' [3] and Imbsen's BDS [4] for the final prestress design, shear and ultimate moment check. A new program developed by LEAP software called CONSPLICE appears to have the capability to perform a complete splice girder bridge design.

	<b>NEBT Post-Tensioned Design Guidelines</b>  <b>Report Number PCINER-01-PTDG</b>	<u>Date Issued</u> June 2001
		Date Revised
		Page Number 7

## Example Bridges

The following bridges have been constructed or are in the process of design using NEBT Post-Tensioned girders. Spans, girder heights and post-tensioning requirements are provided for informational purposes. For actual design many factors such as concrete strength, beam spacing and construction sequence will affect designs.

Bridge	Spans	Girder Height	Post-Tensioning
Husky Bridge, VT	1 simple 42.25 m	1800	56 strands 12.7 mm diameter
ConnDOT Rte. 68 over I-91	2 continuous 51 m	1800	40 / 12.7
Saw Mill River Parkway, NY	1 simple 42.3 m	1800	48 / 12.7
Wallkill Rd. Bridge, Near Syracuse, NY	2 span continuous 54.8, 54.8 m	1800	32 / 12.7
Cranston, RI	3 span continuous	2100	NA
Rte. 94 over Rte. 17 Orange Co. NY	2 span continuous 25 m span lengths	NA	NA
Rte. 17 over Wall Kill River	3 span continuous 54 m span	NA	NA

The following bridges are similar projects that did not use the NEBT.

Bridge	Spans	Girder Height	Post-Tensioning
PCMAC Design Example	2 continuous 43 m	1850 mm	24 / 12.7 strand
Holden Bridge, West Virginia	7 continuous, 64 m	1905	72 / 15.2

NA – This information was not available.

	<b>NEBT Post-Tensioned Design Guidelines</b>	<u>Date Issued</u> June 2001
		Date Revised
	<b>Report Number PCINER-01-PTDG</b>	Page Number 8



# Detailing Guidelines

## Detailing Issues

### Post-Tensioned Duct Clearance

The NEBT has a 180 mm web with 40 min. clearance and permissible use of either a #13 or #16 rebar. This leaves about 65 mm for outer duct diameter.

The girder web should accommodate a variety of post-tensioning systems. Some are shown below with pertinent dimensions.

Post-Tensioning System	Strand No. / Diam.	Outside Duct Diam.
DSI (Dywidag)	9 / 12.7 mm	66 mm
	7 / 15.2	66
VSL EC	7 / 12.7	64
VSL E	10 / 12.7	62
	7 / 15.2	62
Freyssinet	7 / 12.7	60



**Figure 2 - Typical End Anchor for Post-Tension Tendon**

### End Anchorage Block Dimension

The dimension of the end anchorage block along the tendon length is important since it defines the anchorage zone. Most bridge plans we reviewed use roughly 1800 mm. According to the AASHTO Design Specification, the anchorage zone definition as applied to the NEBT should be a minimum of the beam depth. Therefore, for a 1800 mm high NEBT girder, a 1800 mm dimension along the tendon length seems appropriate.

In our opinion the anchorage width only needs to be slightly larger than the local zone reinforcement, which is usually a 300 mm diameter spiral. A **500 mm overall** width of the anchor block is recommended for consistency.

	<b>NEBT Post-Tensioned Design Guidelines</b>	<u>Date Issued</u> June 2001
		Date Revised
	<b>Report Number PCINER-01-PTDG</b>	Page Number 9

## Guideline Drawings

The following Guideline Drawings have been developed:

1. Post-Tensioning Notes
2. Clearance Requirements for Ducts – Sheet 1
3. Clearance Requirements for Ducts – Sheet 2
4. End Block Details – Sheet 1
5. End Block Details – Sheet 2
6. End Block Details – Sheet 3
7. Splice Detail – Tangent Girders
8. Splice Detail – Tangent Girders Sheet 2

	<b>NEBT Post-Tensioned Design Guidelines</b>  <b>Report Number PCINER-01-PTDG</b>	<u>Date Issued</u> June 2001
		Date Revised
		Page Number 10

1. Single End Jacking Permitted, perform on alternate ducts
2. Unless otherwise noted, the prestressing force shall be distributed with an approximately equal amount in each girder and shall be placed symmetrically about the centerline of the structure.
3. No more than 1/2 of the prestressing force in any girder may be applied before an equal force is applied in all of the girders.
4. At no time during the stressing operation will more than 1/6 of the total prestressing force be applied eccentrically about the center line of the structure.
5. Jacking Tension not to exceed .75 f's per Strand
6. Ultimate Strength (f's) = 1862 MPa
7. Local Zone reinforcement to be designed by PT contractor and calculations submitted as working drawings
8. Assume Anchor Set length as 10 mm
9. 13 mm (0.5") or 16 mm (0.6") strand may be used
10. Post Tensioning Contractor to verify that anchorage does not encroach in joint blackout

**Post-Tensioning Notes**

	<b>NEBT Post-Tensioned Design Guidelines</b>	<u>Date Issued</u> June 2001
		Date Revised
	<b>Report Number PCINER-01-PTDG</b>	Page Number 11

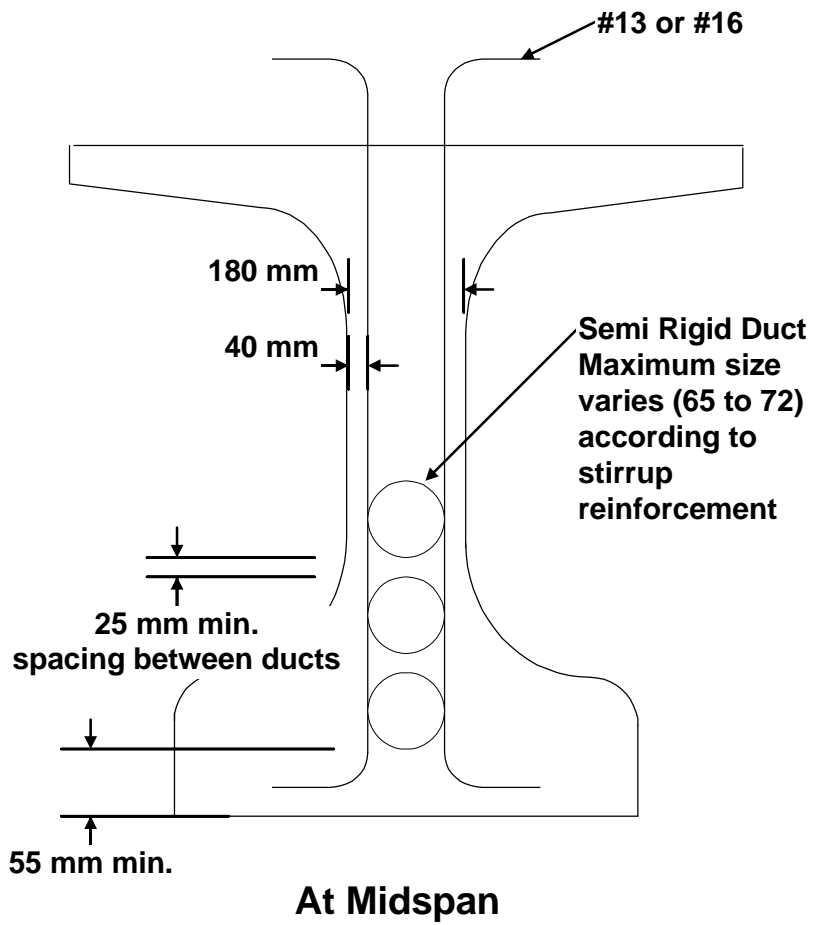

**Clearance Requirements for Ducts - Sheet 1**

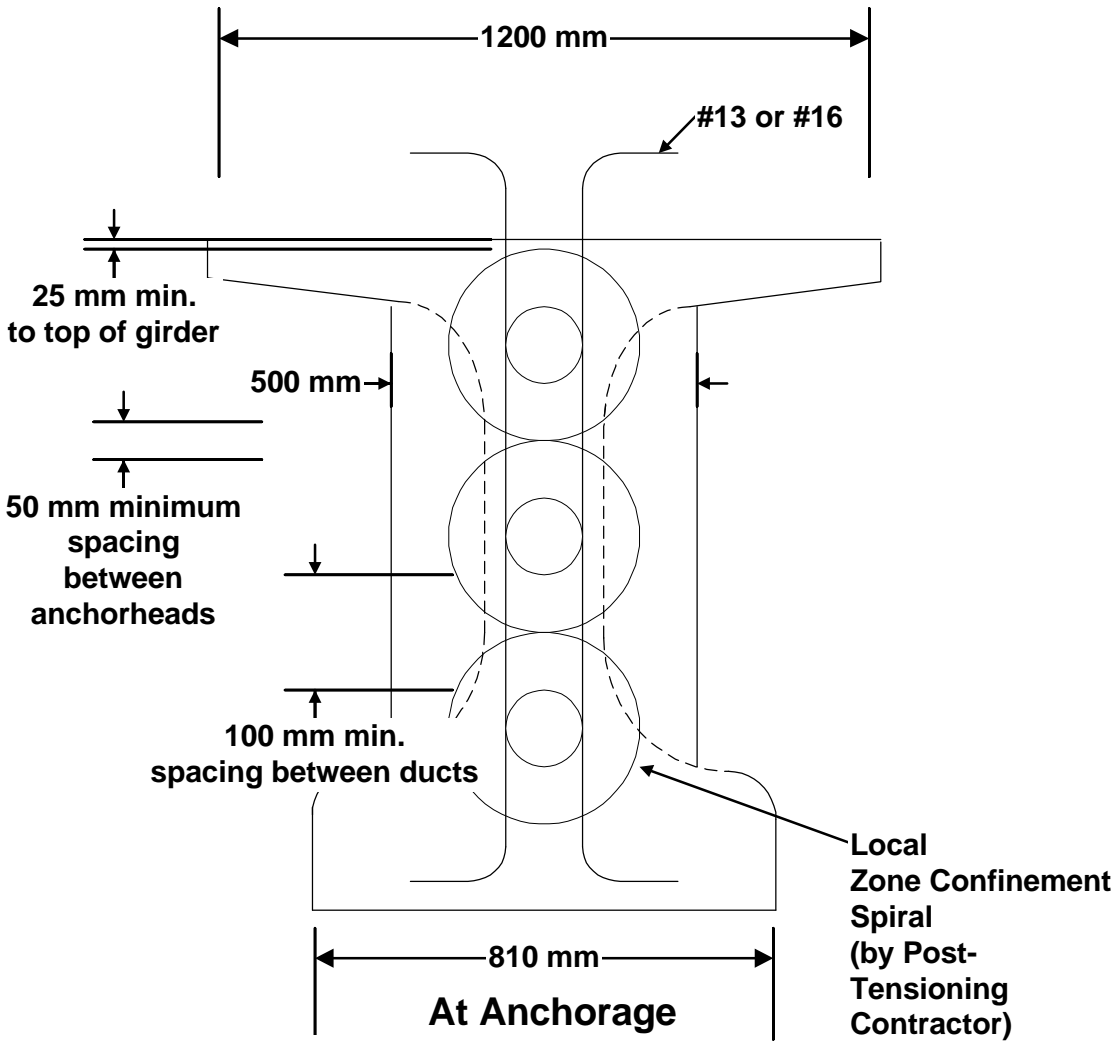

Clearance Requirements for Ducts - Sheet 2

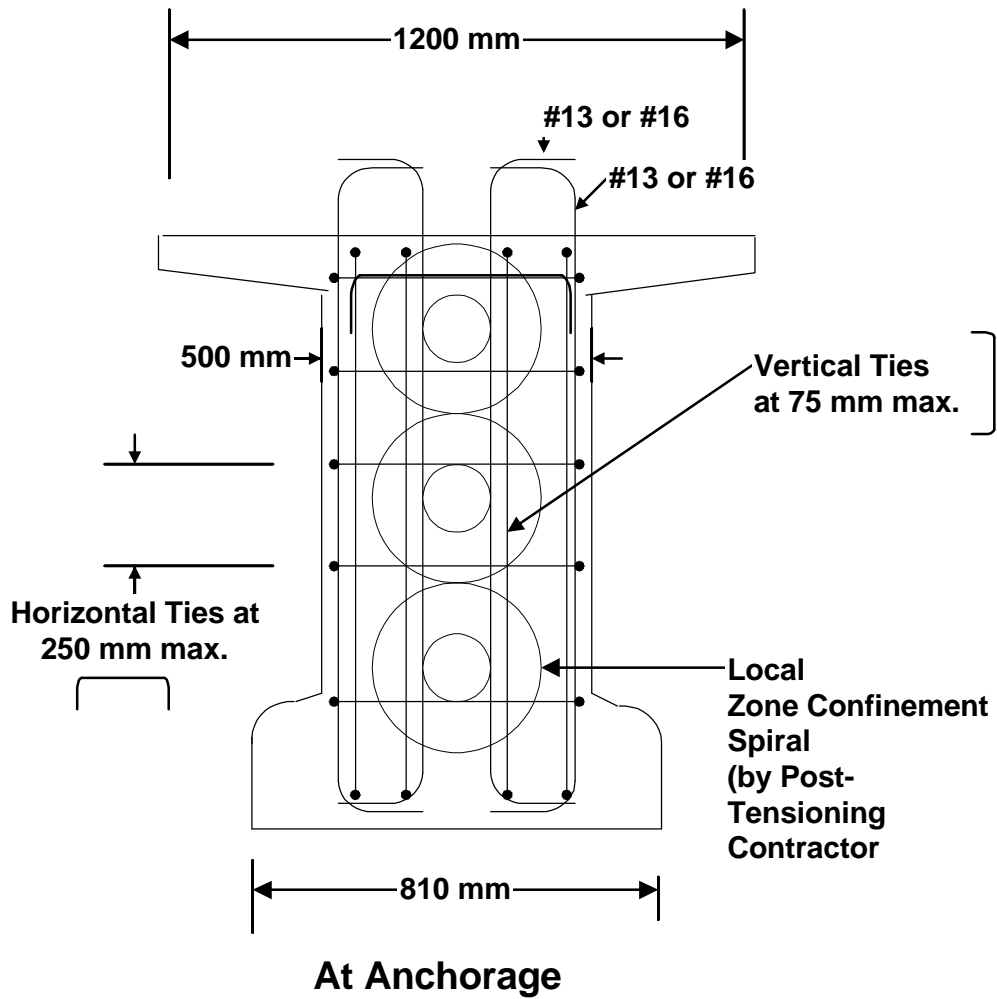

End Block Details - Sheet 1

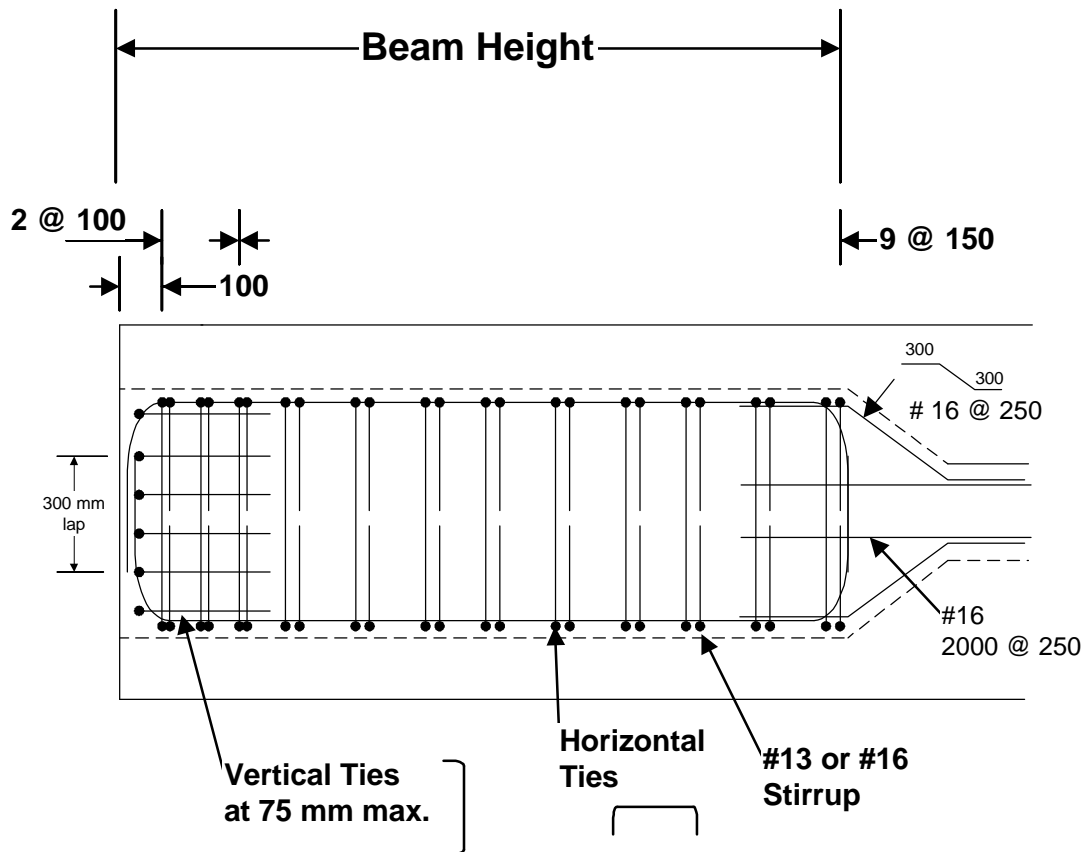

- For Details not shown, see Sheet 1
- Local Zone Reinforcement not shown for clarity

End Block Details - Sheet 2 Plan View

**Recess for Anchorage shall be filled with concrete after stressing is complete. Recess may be stepped.**

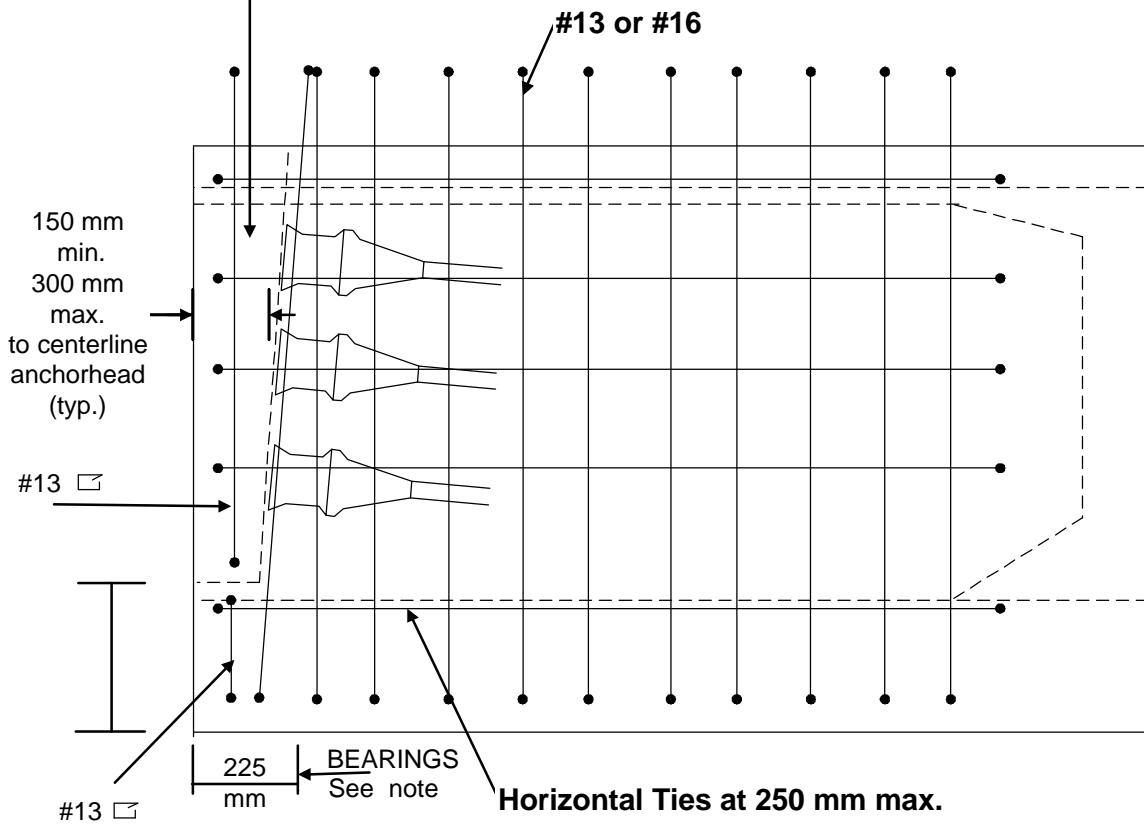

Note: Details for non-integral abutment

**End Block Details - Sheet 3 Elevation View**



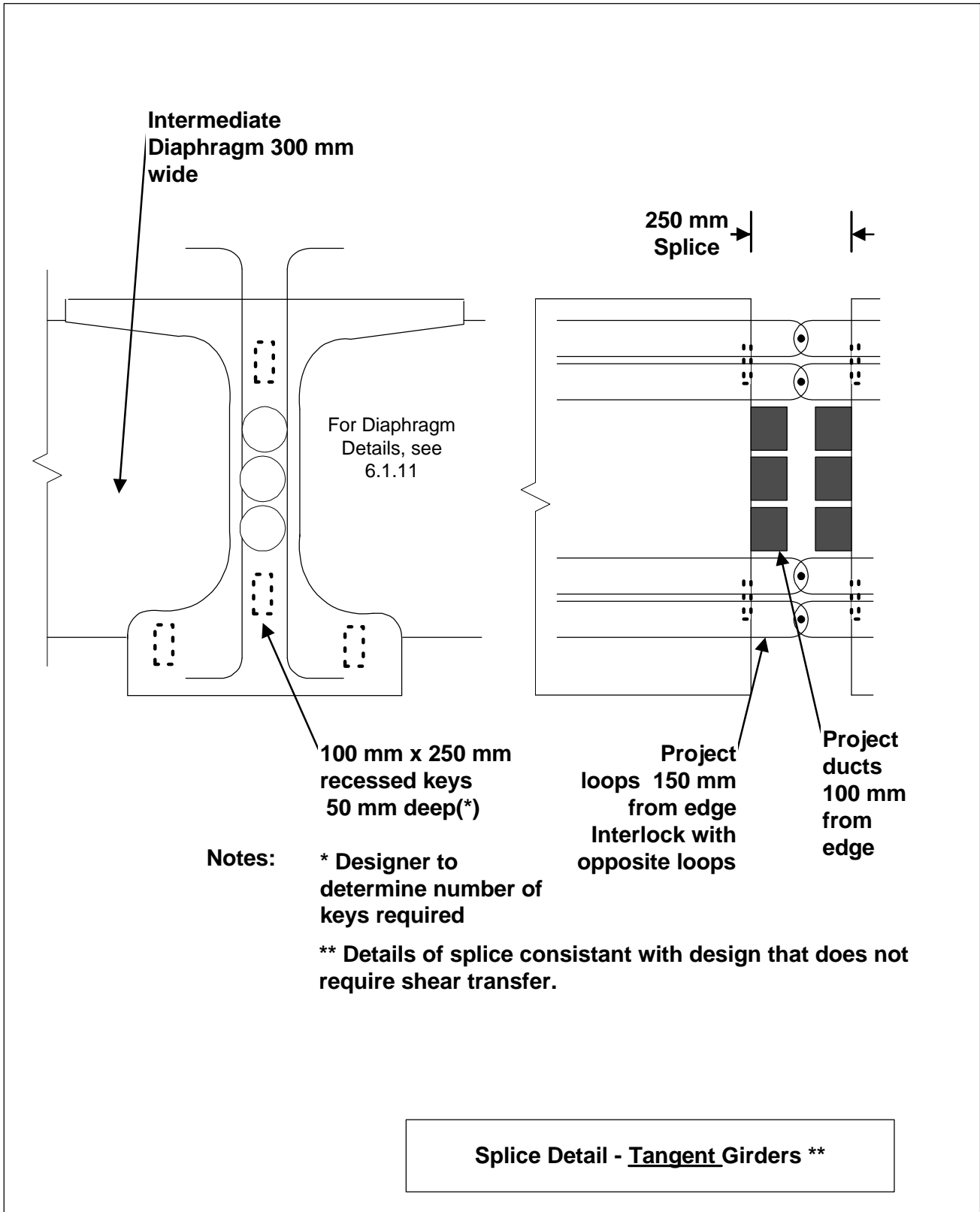

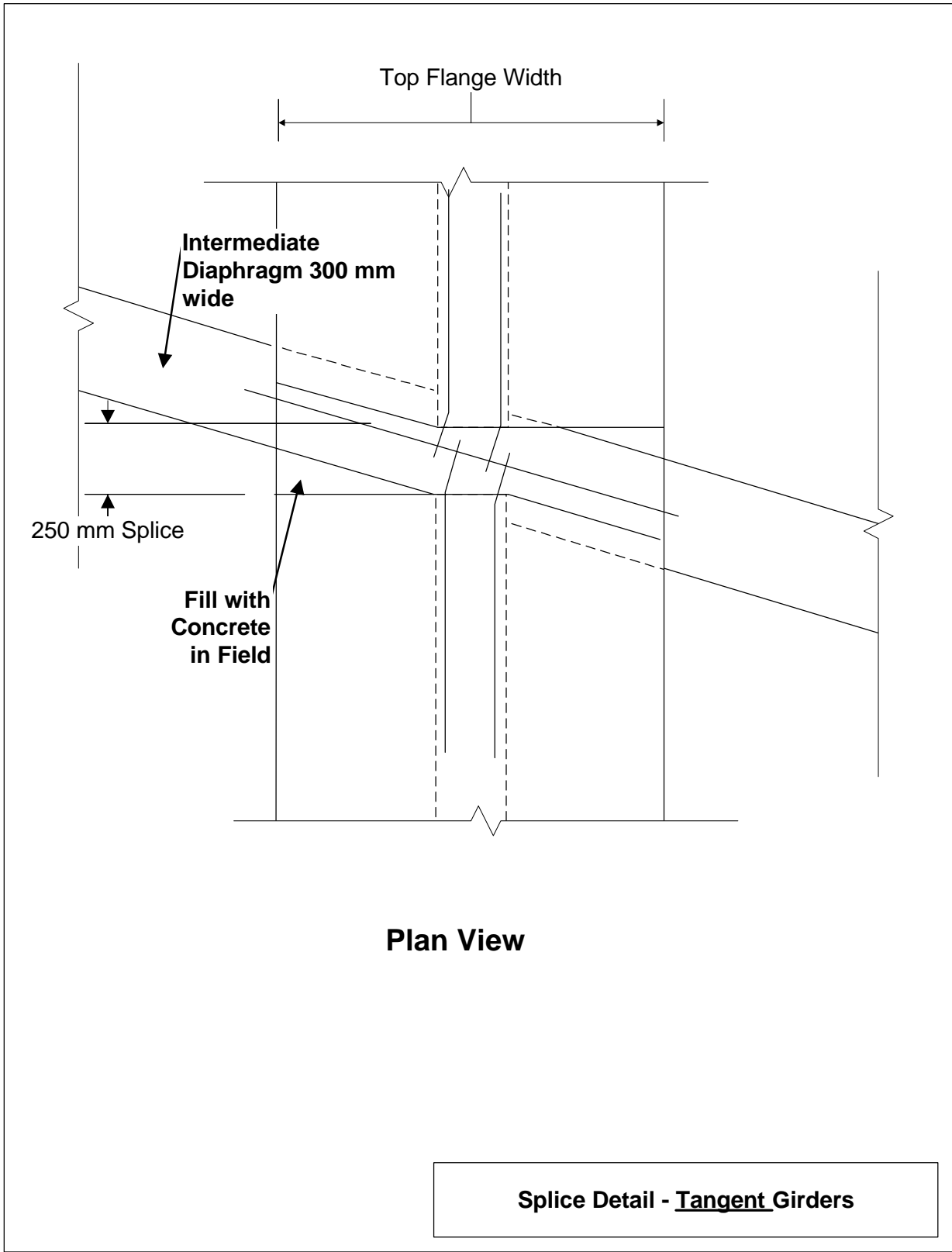

# Example Construction Specification

The following specification was taken from an actual bridge project that utilized the NEBT. It closely follows that recommended by the Post-Tensioning Institute and the Caltrans Construction Specification.

## POST-TENSIONED CONCRETE MATERIALS

### 1.01 PRESTRESSING MATERIALS

A. Post-Tensioning:

1. The superstructure as shown on the plans has been designed using 15.2 mm (0.6 inch) diameter seven-wire, stress-relieved, "Low Relaxation" strand conforming to the requirements of ASTM A416 with a minimum tensile strength of 1860 Mpa (270 ksi).
2. The successful use of these materials is predicated upon the accompanying use of suitable accessory materials. Details for the use of the materials shall be furnished by the manufacturer in connection with shop and working drawing submittals.

B. Prestress Anchorages:

1. All prestressing steel shall be secured at the ends by means of permanent type anchoring devices that have been reviewed and accepted by the Engineer. The anchorages shall develop at least 95 percent of the minimum specified ultimate tensile strength of the prestressing steel, tested in an unbonded state without exceeding anticipated set. Certified copies of test results for the anchorage system to be used shall be supplied to the Engineer at no additional cost. The anchorage shall be so arranged that the prestressing force in the tendon may be verified prior to removal of the stressing equipment.

All anchorage devices shall meet the requirements of AASHTO Specifications for Highway Bridges Division 1, 1996.

2. The load from the anchoring device shall be distributed to the concrete by means of approved devices that will effectively distribute the load to the concrete. Such devices shall conform to the following requirements:
  - a. The average bearing stress in the concrete created by the anchorage plates shall not exceed 21 Mpa (3000 psi) or 90 percent of the compressive strength of the concrete at the time of initial prestress, whichever is less.
  - b. Bending stresses in the plates or assemblies induced by the pull of the prestressing steel shall not exceed the yield point of the material or cause visible distortion of the anchorage plate when 100 percent of the ultimate load is applied as determined by the Engineer.
3. Should the Contractor elect to furnish an anchoring device of a type which is sufficiently large and which is used in conjunction with a steel grillage embedded in the concrete that effectively distributes the compressive stresses to the concrete, the steel distribution plates or assemblies may be omitted.

	<b>NEBT Post-Tensioned Design Guidelines</b>	<u>Date Issued</u> June 2001
		Date Revised
	<b>Report Number PCINER-01-PTDG</b>	Page Number 19

4. Anchorages must be set in a plane normal to the axis of the tendons such that uniform bearing on the concrete is assured. Wedge-type anchors shall not be used in inaccessible locations. Anchorages and anchor fittings shall be permanently protected against corrosion by coating with a coal tar epoxy. Anchorages shall be supplied with a steel reinforcing spiral for those tendons having a prestressing force greater than 1335 kN (300 kips).

C. Samples for Testing:

1. Samples from each manufactured reel of prestressing steel strand and from each lot of anchorage assemblies to be used shall be furnished for testing. With each sample of prestressing strands furnished for testing, there shall be submitted certification stating the manufacturer's minimum guaranteed ultimate tensile strength of the sample furnished.
2. All materials for testing shall be furnished by the Contractor at his expense. The Contractor shall have no claim for additional compensation in the event his work is delayed awaiting approval of the materials furnished for testing.
3. All strand from each manufactured reel to be shipped to the site shall be assigned an individual lot number and shall be tagged in such a manner that each such lot can be accurately identified at the job site. Each lot of anchorage assemblies to be installed at the job site shall also be identified in a similar manner. All unidentified prestressing steel and anchorage assemblies received at the site will be rejected and loss of positive identification of these items at any time will be cause for rejection of their use as intended.
4. The release of any material by the Engineer shall not preclude subsequent rejection if the material is damaged in transit or later damaged or found to be defective.

D. Testing by Contractor:

1. For the purpose of accurately determining the friction loss in the typical strand tendons the Contractor shall test, in place, the first draped tendon for this project:

The test procedure shall consist of stressing the tendon at an anchor assembly with the load cell placed at the dead end permanent anchorage. The test specimen shall be tensioned to 80 percent of ultimate strength in 10 increments and then detensioned from 80 percent of ultimate to 0 in 10 increments. For each increment, the gage pressure, elongation and load cell force shall be recorded. The data shall be furnished to the Engineer. The theoretical elongations shown on the post-tensioning working drawings shall be re-evaluated by the Contractor using the results of the tests and corrected as necessary. Revisions to the theoretical elongations shall be submitted to the Engineer for approval. Apparatus and methods used to perform the tests shall be proposed by the Contractor and shall be subject to the acceptance of the Engineer. The results of the tests (loss due to friction and modulus of elasticity) shall be submitted to the Engineer. Apparatus and methods used to perform the tests shall be proposed by the Contractor and shall be subject to the review and acceptance of the Engineer.

	<b>NEBT Post-Tensioned Design Guidelines</b>	<u>Date Issued</u> June 2001
		Date Revised
	<b>Report Number PCINER-01-PTDG</b>	Page Number 20

E. Protection of Prestressing Steel:

1. All prestressing steel shall be protected against physical damage and rust or other corrosion at all times from manufacture to grouting or encasing in concrete. Prestressing steel that has sustained physical damage at any time will be rejected. The development of visible rust or other corrosion shall be cause for rejection. Any reel of strands that is found to contain any broken wires shall be rejected and the entire reel of strands shall be replaced.
2. Prestressing steel shall be packaged in hermetically sealed containers or shipping forms for protection of the steel against physical damage and corrosion during shipping and storage in accordance with the applicable requirements of ASTM A700. A corrosion inhibitor which prevents rust, when permitted by the Engineer, may be applied directly to the steel. The corrosion inhibitor shall have no deleterious effect on the steel or concrete or bond strength of steel to concrete. Inhibitor carrier-type packaging material shall conform to the provisions of Federal Specifications MIL-P-3420. Packaging or forms damaged from any cause shall be immediately replaced or restored to original condition based on the supplier's instruction.
3. The shipping package or form shall be clearly marked with a statement that the package contains high-strength prestressing steel, the manufacturer's name, order number, package number, length of prestressing steel and that care is to be used in handling. All tags shall be securely affixed to the package container. Also to be marked on the package is the type, kind and amount of corrosion inhibitor used, including the date when placed, safety orders and instructions for use. All strand not so designated will be rejected.
4. During and after prestressing steel installation the Contractor shall prevent all water, rain, snow and/or ice from entering the prestressing ducts.
5. When acceptable prestressing steel for post-tensioning is installed in the ducts after completion of concrete curing, and if stressing and grouting are completed within ten calendar days after the installation of the prestressing steel, rust which may form during said ten days will not be cause for rejection of the steel. Prestressing steel installed, tensioned and grouted in the manner, all within ten calendar days, will not require the use of corrosion inhibitor in the duct following installation of the prestressing steel. Post-tensioning steel installed as above but not grouted within ten calendar days shall be subject to all the requirements in this section pertaining to corrosion protection which includes an accepted water soluble corrosion inhibitor and may include rejection because of rust. The proposed corrosion inhibitor shall be tested by the approved testing laboratory to determine the effectiveness of the corrosion or a vapor phase inhibitor (VPI) powder conforming to the provisions of Federal Specifications MIL-P-3420 inhibitor to provide corrosion protection. Bond testing shall be also performed to prove that the proposed corrosion inhibitor does not impair the bond strength between the cement grout and prestressing steel. Appropriate ventilation is required to avoid toxic effects.

	<b>NEBT Post-Tensioned Design Guidelines</b>  <b>Report Number PCINER-01-PTDG</b>	<u>Date Issued</u> June 2001
		Date Revised
		Page Number 21

F. Ducts:

1. Duct enclosures for prestressing steel, except as otherwise noted, shall be galvanized ferrous metal, mortar tight, and capable of withstanding concrete pressures without deforming and shall not allow the entrance of cement paste during concrete placement. Rigid ducts shall have smooth inner walls and shall be capable of being curved to the proper configuration without crimping or flattening. Semi-rigid ducts shall be corrugated and when tendons are to be inserted after the concrete has been placed their minimum wall thickness shall be as follows: 26 gauge for ducts less than or equal to 65 mm (2-5/8 in.) diameter, 24 gauge for ducts greater than 65 mm (2-5/8 in.) diameter. The ducts shall be accurately bent and placed at the locations shown on the plans or as accepted by the Engineer and shall be securely fastened in place to prevent movement.
2. Rigid ducts may be fabricated with either welded or interlocked seams. Rigid ducts shall be bent without crimping or flattening and shall have sufficient strength to maintain their correct alignment during placing of concrete. Joints between sections of rigid ducts shall be connected with galvanized ferrous metal couplings that are cement paste intrusion proof and that do not result in angle changes at the joints. Transition couplings connecting ducts to anchoring devices shall be galvanized ferrous metal and shall be cement paste intrusion proof and of sufficient strength to prevent distortion or displacement of the ducts during concrete placement.
3. All ducts or anchorage assemblies for permanent prestressing shall be provided with pipes or other suitable connections at each end for the injection of grout after prestressing. All connections to ducts shall be made with galvanized metal or plastic structural fasteners. Plastic components, if selected and approved, shall not react with the concrete or enhance corrosion of the prestressing steel, and shall be free of water soluble chlorides. Grout vents shall be provided at each high point of the tendon profile. The vents shall be mortar tight, taped as necessary, and shall provide means for injection of grout through the vents and for sealing to prevent leakage of the grout. Ends of vents shall be removed one inch below the deck surface after grouting has been completed and the void filled with mortar.
4. Ducts for multi-strand tendons shall be a minimum diameter which provides an inside area at least 2.5 times the net area of the prestressing steel.
5. After installation in the forms, the ends of the ducts shall at all times be covered as necessary to prevent the entry of water and debris and shall be protected to prevent freezing of water in ducts prior to grouting.

G. Grout:

1. Grout shall consist of Portland Cement, water, and admixtures. Portland Cement shall be Type II complying with AASHTO Specification M85. Silicon dioxide (SiO<sub>2</sub>) shall be limited to a maximum of 20 percent. Cement used for grouting shall be fresh and shall not contain lumps or other indication of hydration or "pack set". Water used in the grout shall be potable, clean, and shall be free of deleterious quantities of substances known to be harmful to Portland Cement, or prestressing steel.

	<b>NEBT Post-Tensioned Design Guidelines</b>	<u>Date Issued</u> June 2001
		Date Revised
	<b>Report Number PCINER-01-PTDG</b>	Page Number 22

2. Admixtures, if used, shall impart the properties of low water content, good flowability, minimum bleed and expansion. Admixture formulation shall contain no chemicals in quantities that may have harmful effects on the prestressing steel or cement. Admixtures shall not contain fluorides, sulfites, nitrates, or chlorides and shall be in pre-measured amounts for the batch size to be used.
3. All admixtures shall be used in accordance with the instructions of the manufacturer. Proportions of materials for the post-tensioning grout mix shall be based on tests made on the grout before grouting is begun. Proportions shall be selected based on prior documented experience with similar materials and equipment and under comparable field conditions.
4. The water content shall be the minimum necessary for proper placement. Water-cement ratio shall not exceed 0.45.
5. The Contractor shall furnish to the Engineer the results of tests conducted in independent laboratories, approved by the Engineer, that demonstrate that the grout mixture proposed for use meets the requirements of these specifications. The results furnished shall include a complete description of all component materials and their source including strength of the grout mixture at 24 hours and 28 days.
6. Grout shall be tested by the following method:

<u>Property</u>	<u>Test Method</u>
Shrinkage	ASTM C 827
Compressive strength at 28 days (average of 3 cubes)	ASTM C 109
Initial set of grout	ASTM C 266

The Engineer reserves the right to sample and test the grout before it is used and at any time during the progress of the work. The compressive strength of the grout shall not be less than 21 Mpa (3000 psi) at 7 Days and 42 Mpa (6000 psi) at 28 days. When allowed to stand at placing temperature for 15 minutes, the grout shall not bleed or segregate. At the time of the initial set, the grout shall exhibit a maximum unrestrained expansion of 5 percent of its original volume.

H. Anchor Block Concrete

Anchor block concrete shall be 42 Mpa (6000 psi) compressive strength concrete meeting the following:

1. Water/cement ratio = 0.35
2. Slump (maximum) = 2 inches

The mix design for this concrete shall minimize any potential shrinkage.

	<b>NEBT Post-Tensioned Design Guidelines</b>	<u>Date Issued</u> June 2001
	<b>Report Number PCINER-01-PTDG</b>	Date Revised
		Page Number 23

## CONSTRUCTION METHODS

### 2.01 STRAND INSTALLATION

Strands shall be installed in the ducts so as to avoid entanglement and excessive slack. The placement should be such that would allow a linear elongation of the tendons when jacking from 20% to 100% of the jacking force.

### 2.02 POST-TENSIONING

#### A. Stressing Tendons:

1. All post-tensioning steel shall be tensioned by means of hydraulic jacks so that the force of the prestressing steel shall not be less than the value shown on the approved working drawings. The maximum temporary tensile stress (jacking stress) in prestressing steel shall not exceed 80 percent of the specified minimum ultimate tensile strength of the prestressing steel. The prestressing steel shall be anchored at stresses (initial stresses) that will result in the ultimate retention of permanent forces of not less than those shown on the approved drawings, but in no case shall the initial stress, after anchor set, exceed 70 percent of the specified minimum ultimate tensile strength of the prestressing steel. Permanent force and permanent stress will be considered as the force and stress remaining in the prestressing steel after all losses, including creep and shrinkage of concrete, elastic shortening of concrete, relaxation of steel, losses in post-tensioned prestressing steel due to sequence of stressing, friction and take-up of anchorages, and all other losses peculiar to the method or system of prestressing have taken place or have been provided.
2. Each jack used to stress tendons shall be equipped with a pressure gauge for determining the jacking pressure. The pressure gauge shall have an accurately reading dial at least six inches in diameter and each jack and its gauge shall be calibrated as a unit with the cylinder extension in the approximate position that it will be at final jacking force prior to stressing the initial tendon. Certified calibration charts shall be furnished by an independent laboratory with each jack and gauge used on the project. Certified calibration shall be made at the start of the work and every six months thereafter, or as requested by the Engineer. The calibration shall be done while the jack is in the identical configuration as will be used on the site, e.g., same length hydraulic lines. At the option of the Contractor, calibrations subsequent to the initial ram calibration by the load cell may be accomplished by the use of a master gauge. The master gauge shall be supplied by the Contractor in a protective waterproof container capable of protecting the calibration of the master gauge during shipment to a laboratory. The Contractor shall provide a quick-attach coupler next to the permanent gauge in the hydraulic line which enables the quick and easy installation of the master gauge to verify the permanent gauge readings. The master gauge shall remain in the possession of and be calibrated by the Engineer for the duration of the project. Any repair of the rams, such as replacing the seals or changing the length of the hydraulic lines, is cause for recalibration of the ram with a load cell. No extra compensation will be allowed for the initial or subsequent ram calibrations or for the use and required calibrations of a master gauge.

	<b>NEBT Post-Tensioned Design Guidelines</b>  <b>Report Number PCINER-01-PTDG</b>	<u>Date Issued</u> June 2001
		Date Revised
		Page Number 24



3. Post-tensioning forces shall not be applied until the concrete has attained the compressive strength specified as determined by the cylinder tests.
4. The tensioning process shall be so conducted that tension being applied and the elongation of the post-tensioning steel may be measured at all times. A record shall be kept of gauge pressures and elongations at all times and shall be submitted to the Engineer. The post-tensioning force may be verified as deemed necessary by the Engineer. The tendon force measured by gauge pressure shall agree within five percent from the theoretical elongation. The entire operation shall be checked and the source of error determined and remedied to the satisfaction of the Engineer before proceeding with the work. Elongations shall be measured to the nearest 1/16 inch. Equipment for tensioning the tendons must be furnished by the manufacturer of the system (tendons and anchorages). The Engineer, at his discretion and without additional compensation to the Contractor, may require additional bench tests and/or friction tests, should the agreement between pressure gauge readings and measured elongations fall outside the acceptable tolerances.
5. The contract plans were prepared based on the assumption of a friction coefficient of 0.25, a wobble coefficient of 0.0002, anchor sets of 0.25 inches for longitudinal strands and modulus of elasticity of 193,000 Mpa (28,000 ksi). The expected friction coefficient shall also appear on the shop plans for all types of tendons.

**B. Grouting:**

1. After the tensioning of all tendons has been completed and the prestressing steel has been anchored, the annular space between the duct and the tendons shall be grouted. The tendons shall be protected against corrosion by a plug at each end to prevent the passage of air, and such plugs shall be left in place until the tendon is grouted.
2. The grouting equipment shall include a mixer capable of continuous mechanical mixing which will produce a grout free of lumps and undispersed cement. The equipment shall be able to pump the mixed grout in a manner which will comply with all provision hereinafter specified. Accessory equipment which will provide for accurate solid and liquid measurements shall be provided to batch all materials. The pumps shall be positive displacement type and be able to produce an outlet pressure of at least 1035 Mpa (150 psi). The pump shall have seals adequate to prevent introduction of oil, air, or other foreign substance into the grout, and to prevent loss of grout or water. A pressure gauge having a full scale reading of no greater than 2070 Mpa (300 psi) shall be placed at some point in the grout line between the pumping outlet and the duct inlet. The grouting equipment shall contain a screen having clear openings of 3 mm (0.125 inch) maximum size to screen the grout prior to its introduction into the grout pump. If a grout with an additive is used, a screen opening of 5 mm (3/16 inch) is satisfactory. This screen shall be easily accessible for inspection and cleaning. The grouting equipment shall utilize gravity feed to the pump inlet from a hopper attached to and directly over it. The hopper must be kept at least partially full of grout at all times during the pumping operation to prevent air from being drawn into the post-tensioning duct. Under normal conditions, the grout equipment shall be capable of continuously grouting the longest tendon on the project in not more than twenty minutes.

	<b>NEBT Post-Tensioned Design Guidelines</b>	<u>Date Issued</u> June 2001
		Date Revised
	<b>Report Number PCINER-01-PTDG</b>	Page Number 25

3. Water shall be added to the mixer first, followed by Portland Cement and admixture, or as required by the admixture manufacturer. Mixing shall be of such duration as to obtain a uniform thoroughly blended grout, without excessive temperature increase or loss of expansive properties of the admixture. The grout shall be continuously agitated until it is pumped. Water shall not be added to increase grout flowability which has been decreased by delayed use of the grout. Proportions of materials shall be based on tests made on the grout before grouting is begun, or may be selected based on prior documented experience with similar materials and equipment and under comparable field conditions (weather, temperature, etc.). The water content shall be the minimum necessary for proper placement, and shall not exceed the water-cement ratio of 0.45 or approximately five gallons of water per sack (94 pounds) of cement. The pumpability of the grout may be determined by the Engineer in accordance with the U.S. Corps of Engineers Method CRD-C79. When this method is used, the efflux time of the grout sample immediately after mixing shall not be less than eleven seconds. The flow cone test does not apply to grout which incorporates a thixotropic additive.
  
4. All grout openings shall be open when grouting starts. Grout shall be allowed to flow from the first vent after the inlet pipe until any residual flushing water or entrapped air has been removed, at which time the vent should be capped or otherwise closed. Pressure at remaining vents shall not exceed 1725 Mpa (250 psi). If the actual grouting pressure exceeds the maximum recommended pumping pressure, grouting may be injected at any vent which has been, or is ready to be, capped as long as a one-way flow of grout is maintained. If this procedure is used, then the vent which is to be used for injection shall be fitted with a positive shutoff.
  
5. When one-way flow of grout cannot be maintained as outlined above, the grout shall be immediately flushed out of the duct with water. Grout shall be pumped through the duct and continuously wasted at the outlet pipe until no visible slugs of water or air are ejected and efflux time of the ejected grout shall not be less than the injected grout. To insure that the tendon remains filled with grout, the outlet and/or inlet shall be closed. Plugs, caps or valves thus required shall not be removed or opened until the grout has set. In temperatures below 32°F, ducts shall be kept free of water to avoid damage due to freezing. The temperature of the concrete shall be 35°F or higher from the time of grouting until job cured two inch cubes of grout reach a minimum compressive strength of 800 psi. Grout shall not be above 90°F during mixing or pumping. If necessary, the mixing water shall be cooled.

	<b>NEBT Post-Tensioned Design Guidelines</b>	<u>Date Issued</u> June 2001
		Date Revised
	<b>Report Number PCINER-01-PTDG</b>	Page Number 26

## References

1. Massachusetts Highway Department, 'Bridge Manual Part II' Draft February 1999. NEBT's and Spread Boxes including Semi-Integral Abutment Details
2. Caltrans-PCMAC Informational Draft, 'Continuous Spliced Precast Girders Design Examples Utilizing the Integral Cap Precast Girder Bridge System
3. ADAPT Computer Analysis Program, [www.ADAPTsoft.com](http://www.ADAPTsoft.com)
4. Imbsen BDS (Bridge Design System) Computer Program, [www.imbsen.com](http://www.imbsen.com)
5. LEAP Software CONSPLICE PT, LRFD and AASHTO Standard Design and Analysis of Spliced Prestressed/Precast Bridge Girders and CIP Concrete Slabs, [www.leapsoft.com](http://www.leapsoft.com).
6. Precast Concrete Institute Bridge Manual, 1997

	<b>NEBT Post-Tensioned Design Guidelines</b>  <b>Report Number PCINER-01-PTDG</b>	<u>Date Issued</u> June 2001
		Date Revised
		Page Number 27